

NOTES:

1. ALL DIMENSIONS ARE IN INCHES.

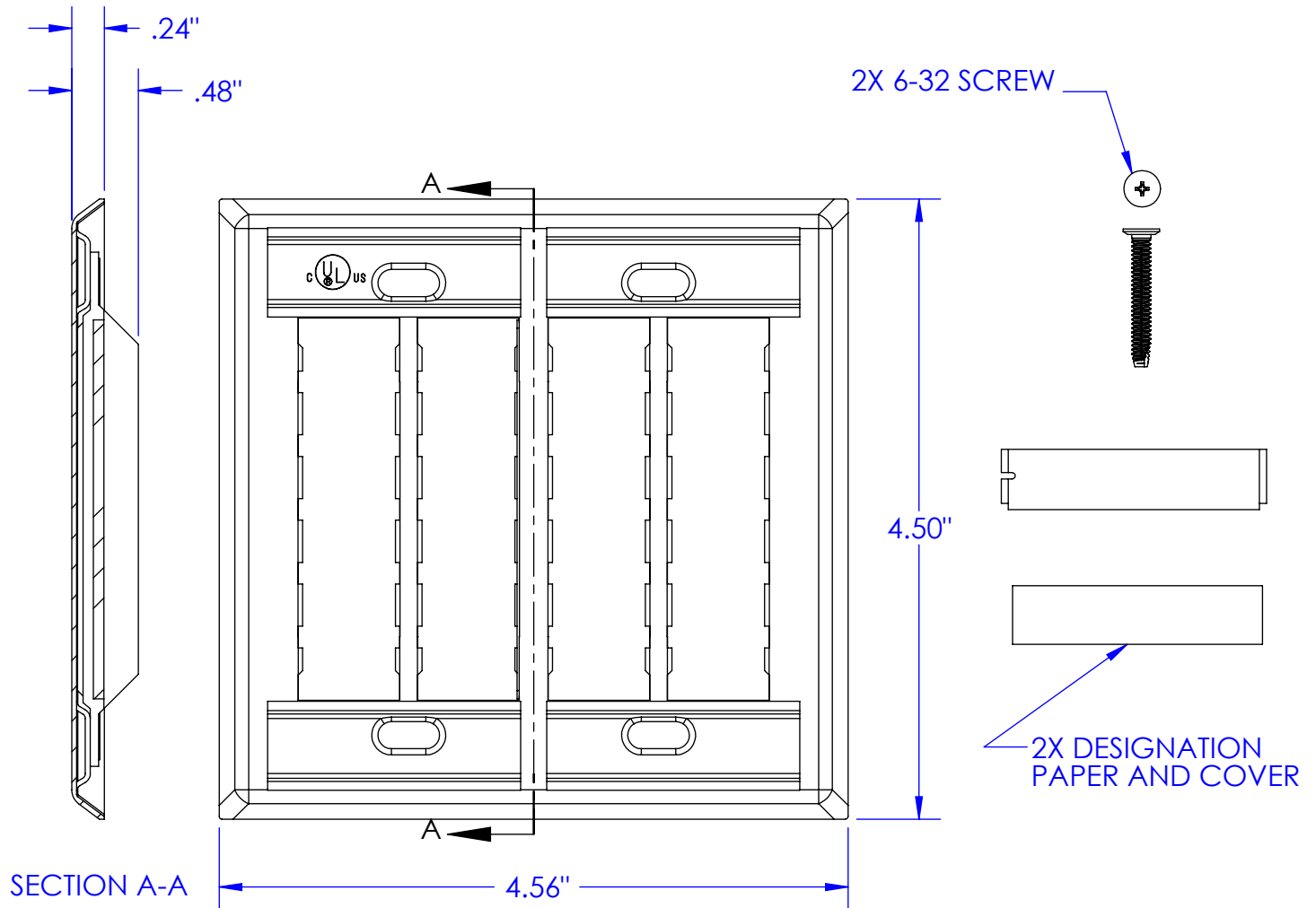

<p>*** NOTICE ***</p> <p>THIS DOCUMENT CONTAINS CONFIDENTIAL AND/OR PROPRIETARY INFORMATION INTENDED FOR USE ONLY BY THE INDIVIDUAL(S) PROVIDED. NEITHER THIS DOCUMENT, NOR ANY INFORMATION CONTAINED HEREIN, MAY BE COPIED, DISTRIBUTED, DISCLOSED TO ANY THIRD PARTY OR USED IN ANY MANNER OTHER THAN FOR WHICH IT HAS BEEN PROVIDED, WITHOUT THE PRIOR WRITTEN CONSENT OF ORTRONICS, INC. MANUFACTURING RELEASE, PRODUCT SPECIFICATIONS AND STANDARDS ARE SUBJECT TO CHANGE WITHOUT NOTICE.</p>					<p>125 EUGENE O'NEILL DRIVE NEW LONDON, CT 06320 TEL: 860-445-3800 FAX: 860-405-2990 WWW.ORTRONICS.COM</p>	
			<p>TITLE</p> <p>FP, TJ, DG, 12 HOLE, FLUSH, SS, LABEL FIELD, 4.5" x 4.5"</p>			
	NAME	DATE	SIZE	CAD FILE	DWG NO	REV
DWN	S. LEVESQUE	07/13/06	A	403STJ212C	OR-403STJ212	04
CHK	COLLELO	07/13/06	SCALE	NONE	WEIGHT	SHEET
APPR	M. MARTICH	07/13/06				1 OF 1