



EXCEPTIONAL SUPPORT & PROTECTION™

Dry Contact Controlled Rackmount Power Strips



EIA/TIA Compliant



Remotely Controlled Rackmount power distribution unit with 2-stage surge suppression

Features

- No computer required; use existing control system or remote power switches
- Built-in 2-stage surge suppression with surge status notification
- 9 outlets - 1 on front (unswitched), 8 on rear
- Either 2 or 6 contact-closure controlled outlets on rear, depending on model
- Settings for momentary or maintained control style, normally open or normally closed
- Controlled Outlets LED power status indicators
- Illuminated master power switch

PDC-915R-2



PDC-915R-6



Architects and Engineers' Specifications

EIA compliant 19" Rackmount power strip shall be Middle Atlantic Products model # PDC-915R-_(2,6), with a 15 amp capacity, 2-stage differential and common mode surge and spike protection with surge status notification. Rackmount power strip shall operate on 120 volt AC/60Hz supply. Rackmount power strip shall include 9' SignalSAFE™ 4/3 power cord terminated with 5-15P. Rackmount power strip shall include 1 front outlet and have _ (2, 6) contact-closure controlled outlets on rear, and shall provide settings for momentary or maintained, and normally open or normally closed dry contact control. Rackmount power strip shall occupy one rackspace and be constructed of 18-gauge phosphate pre-treated steel with a black powdercoat finish. Rackmount power strip shall comply with the requirements of RoHS EU Directive 2002/95/EC. Rackmount power strip shall be GREENGUARD Indoor Air Quality Certified for Children and Schools. Rackmount power strip shall be manufactured by an ISO 9001 registered company. Rackmount power strip shall be warranted to be free from defects in materials and workmanship under normal use and conditions for a period of 3 years. Rackmount power distribution unit shall be ETL listed to UL standard 1419, UL 60950-1 and UL 60065 in the US; CSA standard 60950-1, and CSA C22.2 No. 60065 in Canada.

CUSTOMIZABLE SPECIFICATION CLIPS AVAILABLE AT MIDDLEATLANTIC.COM

Remotely Controlled Rackmount power distribution unit with 2-stage surge suppression basic dimensions

All dimensions in inches unless otherwise noted [All dimensions in brackets are in millimeters]

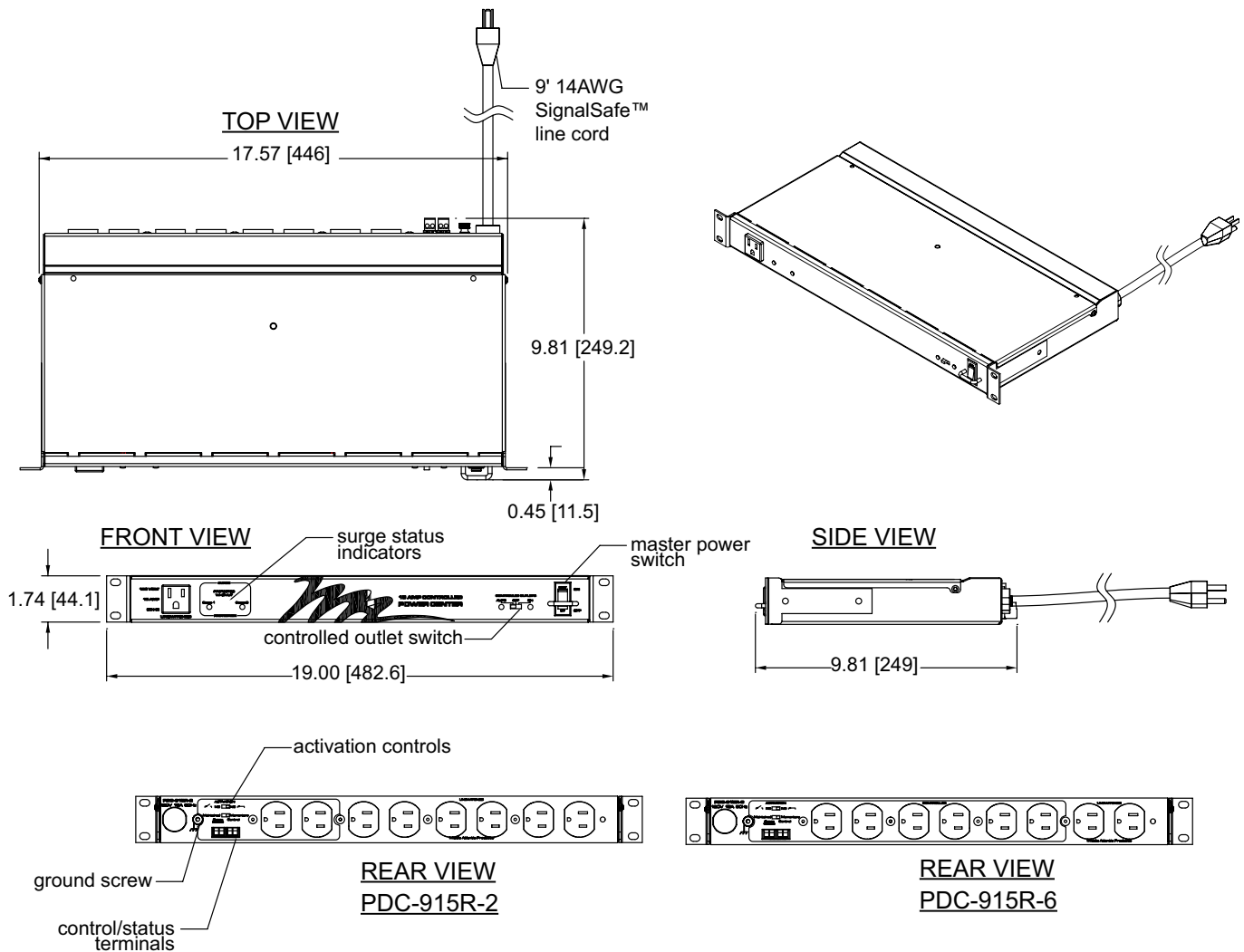

Maximum Derated Load (North America): 12 Amps

